

SERIES W2S ACCESS DOOR



www.HallidayProducts.com
 Phone: (800) 298-1027
 Local: (407) 298-4470
 Sales@HallidayProducts.com

STANDARD FEATURES:

- 300 LBS. PER SQ. FT. LOAD RATING (1464 KG PER SQ. METER LOAD RATING)
- EXTRUDED ALUMINUM CHANNEL FRAME
- DOUBLE LEAF CONSTRUCTION
- AUTO-LOCK T-316 STAINLESS STEEL HOLD OPEN ARM WITH RELEASE HANDLE
- T-316 STAINLESS STEEL HINGES AND ATTACHING HARDWARE
- T-316 STAINLESS STEEL SLAM LOCK WITH REMOVABLE KEY
- STAINLESS STEEL COMPRESSION SPRING ASSIST
- BUILT-IN EPDM CUSHION/GASKET
- NON-OZONE DEPLETING BITUMINOUS COATING
- RECESSED LIFTING HANDLE
- LIFETIME GUARANTEE

STANDARD SIZES

QTY.	MODEL NO.	A DIM INCHES (MM)	C DIM INCHES (MM)	UNIT WT. LBS. (KG)
	W2S4242	42 (1067)	42 (1067)	108 (48)
	W2S4842	48 (1219)	42 (1067)	115 (52)
	W2S4848	48 (1219)	48 (1219)	126 (57)
	W2S5442	54 (1372)	42 (1067)	124 (56)
	W2S5448	54 (1372)	48 (1219)	136 (62)
	W2S5454	54 (1372)	54 (1372)	149 (68)
	W2S6030	60 (1524)	30 (762)	102 (46)
	W2S6036	60 (1524)	36 (914)	116 (53)
	W2S6042	60 (1524)	42 (1067)	132 (60)
	W2S6048	60 (1524)	48 (1219)	148 (67)
	W2S6054	60 (1524)	54 (1372)	162 (73)
	W2S6060	60 (1524)	60 (1524)	177 (80)
	W2S6636	66 (1676)	36 (914)	126 (57)
	W2S6648	66 (1676)	48 (1219)	160 (73)
	W2S7236	72 (1829)	36 (914)	135 (61)
	W2S7242	72 (1829)	42 (1067)	154 (70)
	W2S7248	72 (1829)	48 (1219)	171 (78)
	W2S7254	72 (1829)	54 (1372)	188 (85)
	W2S7260	72 (1829)	60 (1524)	203 (92)

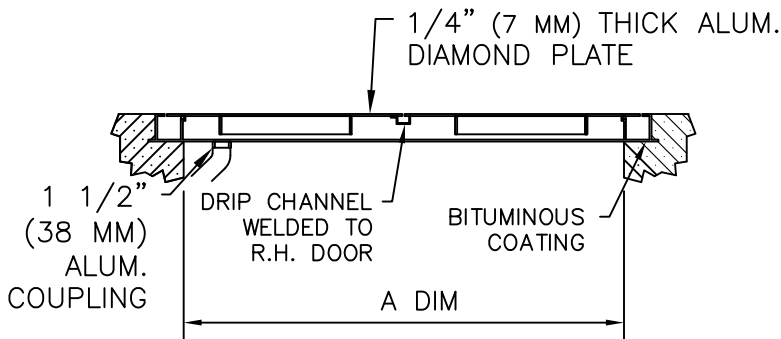
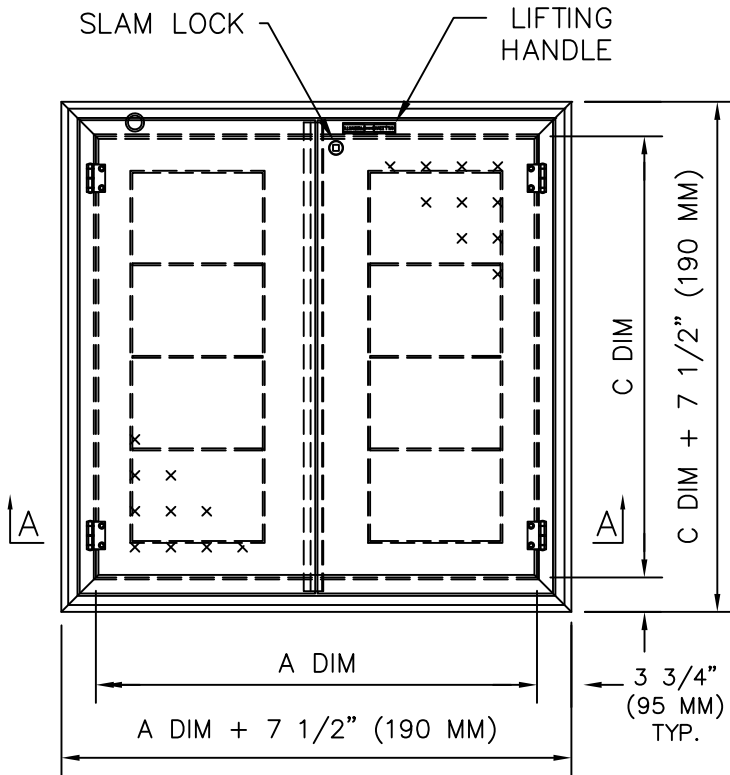

SECTION A-A

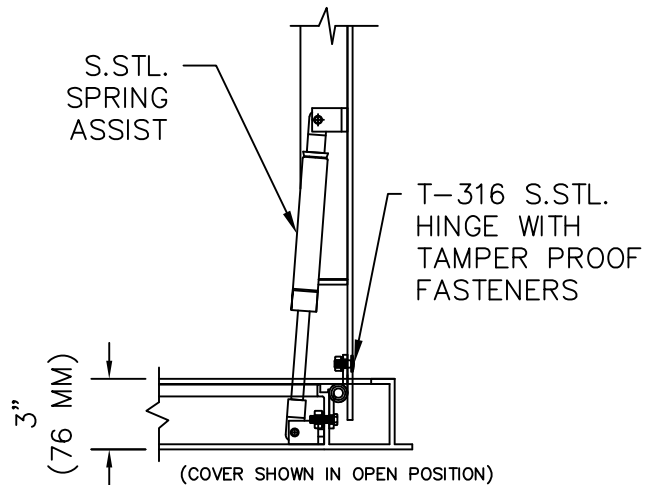

DETAIL