

SERIES W2R ACCESS DOOR



www.HallidayProducts.com
 Phone: (800) 298-1027
 Local: (407) 298-4470
 Sales@HallidayProducts.com

STANDARD FEATURES:

- 300 LBS. PER SQ. FT. LOAD RATING
 (1464 KG PER SQ. METER LOAD RATING)
- EXTRUDED ALUMINUM CHANNEL FRAME
- DOUBLE LEAF CONSTRUCTION
- AUTO-LOCK T-316 STAINLESS STEEL
 HOLD OPEN ARM WITH RELEASE HANDLE
- T-316 STAINLESS STEEL HINGES AND ATTACHING HARDWARE
- NON-CORROSIVE PADLOCK BAR
- RECESSED LIFTING HANDLE
- LIFETIME GUARANTEE

STANDARD SIZES

QTY.	MODEL NO.	A DIM INCHES (MM)	C DIM INCHES (MM)	UNIT WT. LBS. (KG)
	W2R4242	42 (1067)	42 (1067)	108 (48)
	W2R4842	48 (1219)	42 (1067)	115 (52)
	W2R4848	48 (1219)	48 (1219)	126 (57)
	W2R5442	54 (1372)	42 (1067)	124 (56)
	W2R5448	54 (1372)	48 (1219)	136 (62)
	W2R5454	54 (1372)	54 (1372)	149 (68)
	W2R6030	60 (1524)	30 (762)	102 (46)
	W2R6036	60 (1524)	36 (914)	116 (53)
	W2R6042	60 (1524)	42 (1067)	132 (60)
	W2R6048	60 (1524)	48 (1219)	148 (67)
	W2R6054	60 (1524)	54 (1372)	162 (73)
	W2R6060	60 (1524)	60 (1524)	177 (80)
	W2R6636	66 (1676)	36 (914)	126 (57)
	W2R6648	66 (1676)	48 (1219)	160 (73)
	W2R7236	72 (1829)	36 (914)	135 (61)
	W2R7242	72 (1829)	42 (1067)	154 (70)
	W2R7248	72 (1829)	48 (1219)	171 (78)
	W2R7254	72 (1829)	54 (1372)	188 (85)
	W2R7260	72 (1829)	60 (1524)	203 (92)

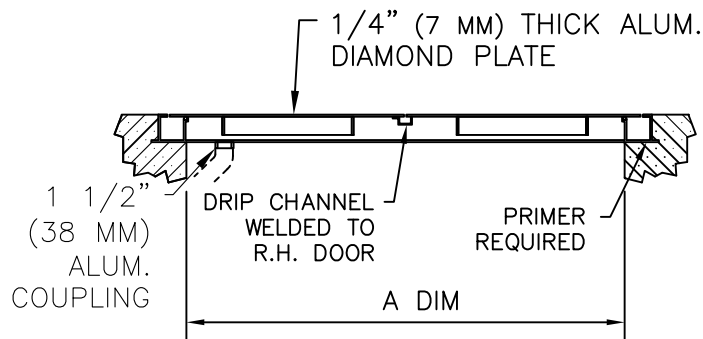
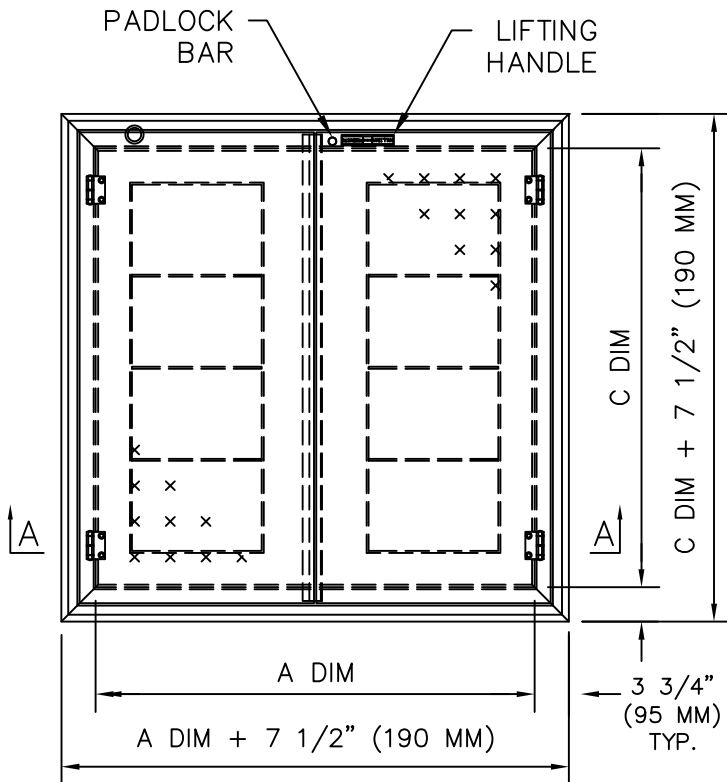

SECTION A-A

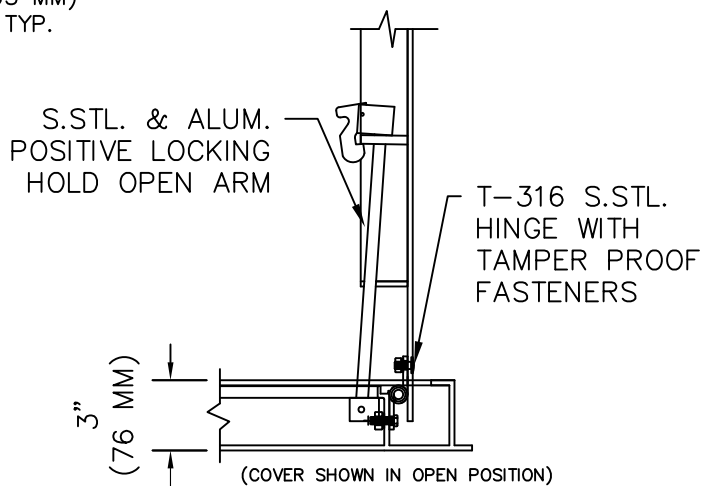

DETAIL