

SERIES W1R ACCESS DOOR



www.HallidayProducts.com
 Phone: (800) 298-1027
 Local: (407) 298-4470
 Sales@HallidayProducts.com

STANDARD FEATURES:

- 300 LBS. PER SQ. FT. LOAD RATING
 (1464 KG PER SQ. METER LOAD RATING)
- EXTRUDED ALUMINUM CHANNEL FRAME
- SINGLE LEAF CONSTRUCTION
- AUTO-LOCK T-316 STAINLESS STEEL
 HOLD OPEN ARM WITH RELEASE HANDLE
- T-316 STAINLESS STEEL HINGES AND ATTACHING HARDWARE
- NON-CORROSIVE PADLOCK BAR
- RECESSED LIFTING HANDLE
- LIFETIME GUARANTEE

STANDARD SIZES

QTY.	MODEL NO.	A DIM INCHES (MM)	C DIM INCHES (MM)	UNIT WT. LBS. (KG)
	W1R2424	24 (610)	24 (610)	46 (20)
	W1R2430	24 (610)	30 (762)	51 (23)
	W1R2436	24 (610)	36 (914)	61 (28)
	W1R2442	24 (610)	42 (1067)	77 (35)
	W1R2448	24 (610)	48 (1219)	85 (39)
	W1R3030	30 (762)	30 (762)	62 (28)
	W1R3036	30 (762)	36 (914)	69 (31)
	W1R3042	30 (762)	42 (1067)	77 (35)
	W1R3048	30 (762)	48 (1219)	85 (39)
	W1R3054	30 (762)	54 (1372)	99 (45)
	W1R3060	30 (762)	60 (1524)	102 (46)
	W1R3636	36 (914)	36 (914)	78 (35)
	W1R3642	36 (914)	42 (1067)	89 (40)
	W1R3648	36 (914)	48 (1219)	97 (44)
	W1R3654	36 (914)	54 (1372)	107 (49)
	W1R3660	36 (914)	60 (1524)	116 (53)
	W1R3666	36 (914)	66 (1676)	126 (57)
	W1R3672	36 (914)	72 (1829)	135 (61)
	W1R4242	42 (1067)	42 (1067)	108 (49)

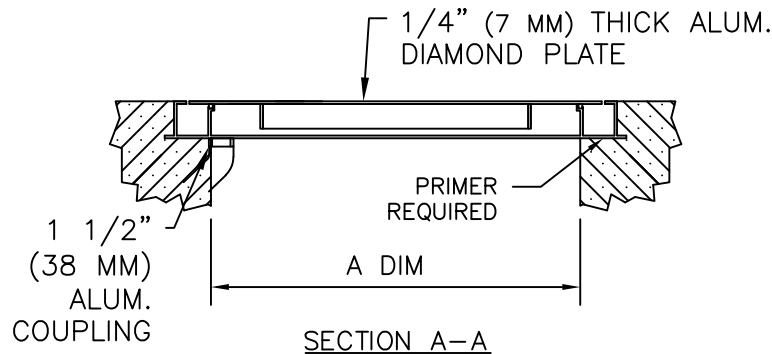
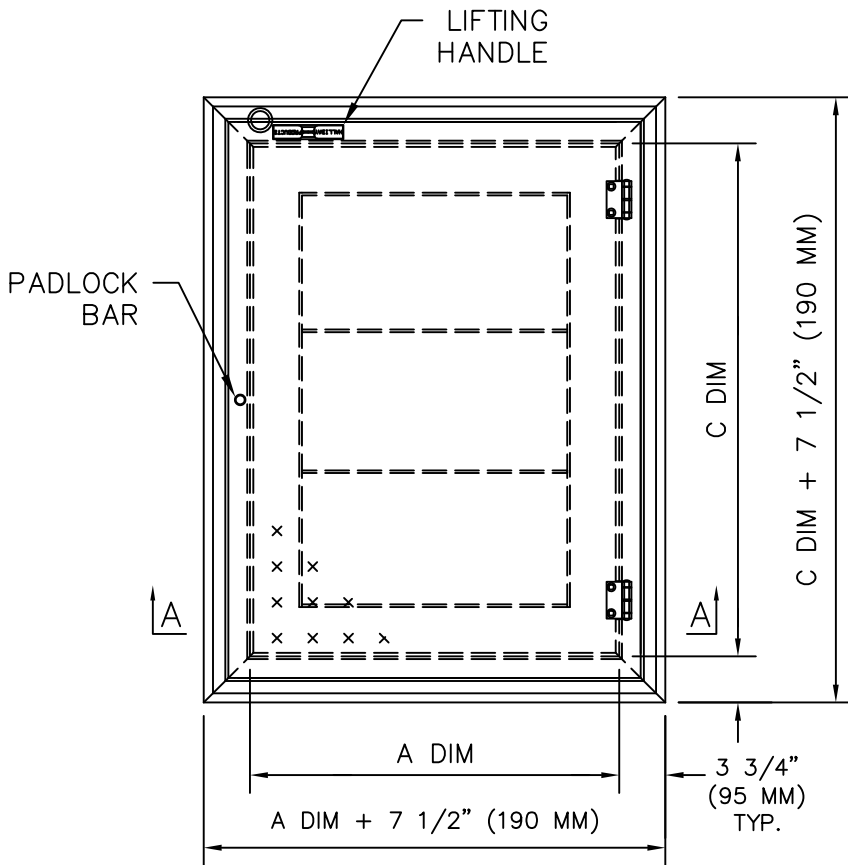

S.STL. & ALUM.
 POSITIVE LOCKING
 HOLD OPEN ARM

