

# SERIES H1W ACCESS DOOR



www.HallidayProducts.com  
 Phone: (800) 298-1027  
 Local: (407) 298-4470  
 Sales@HallidayProducts.com

## STANDARD FEATURES:

- H20 LOAD RATING (SEE NOTES)
- EXTRUDED ALUMINUM CHANNEL FRAME
- SINGLE LEAF CONSTRUCTION
- AUTO-LOCK T-316 STAINLESS STEEL HOLD OPEN ARM WITH RELEASE HANDLE
- T-316 STAINLESS STEEL HINGES AND ATTACHING HARDWARE
- T-316 STAINLESS STEEL SLAM LOCK WITH REMOVABLE KEY
- STAINLESS STEEL COMPRESSION SPRING ASSIST
- RECESSED LIFTING HANDLE
- LIFETIME GUARANTEE

## STANDARD SIZES

QTY.	MODEL NO.	A DIM INCHES (MM)	C DIM INCHES (MM)	UNIT WT. LBS. (KG)
	H1W2424	24 (610)	24 (610)	72 (33)
	H1W2430	24 (610)	30 (762)	90 (41)
	H1W2436	24 (610)	36 (914)	108 (49)
	H1W2442	24 (610)	42 (1067)	126 (57)
	H1W3030	30 (762)	30 (762)	113 (51)
	H1W3036	30 (762)	36 (914)	135 (61)
	H1W3042	30 (762)	42 (1067)	158 (72)
	H1W3048	30 (762)	48 (1219)	180 (82)
	H1W3636	36 (914)	36 (914)	162 (73)
	H1W3642	36 (914)	42 (1067)	189 (86)
	H1W3648	36 (914)	48 (1219)	216 (98)

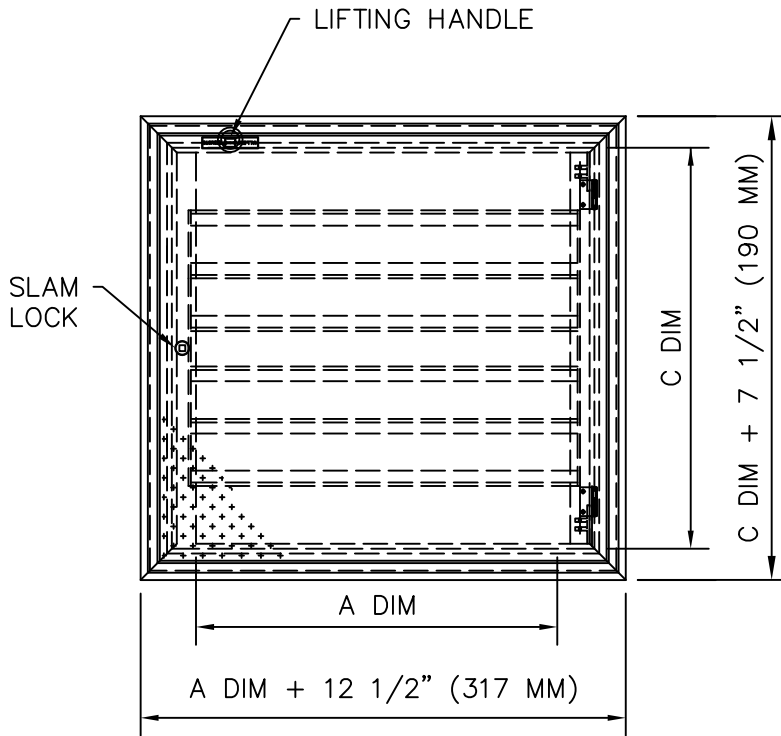

## NOTES:

- 1) SUITABLE FOR USE IN OFF STREET LOCATION WHERE NOT SUBJECTED TO HIGH DENSITY TRAFFIC.
- 2) PROVIDE A FULL BED OF CLASS "A" CONCRETE UNDER FRAME AND SUPPORT ANGLES.

