

SERIES G1A AND G1B

SLIDE GATE



www.HallidayProducts.com
 Phone: (800) 298-1027
 Local: (407) 298-4470
 Sales@HallidayProducts.com

STANDARD FEATURES:

- ONE-PIECE 6061-T6 EXTRUDED ALUMINUM FRAME
- ONE-PIECE POLYMER GUIDE
- 1/4" (7 MM) THICK 6061-T6 ALUMINUM GATE REINFORCED AS REQUIRED TO DEFLECT NO MORE THAN 1/360th OF SPAN (5' MAX HEAD PRESSURE)
- LOW COEFFICIENT OF FRICTION
- DEEP SEATING FOR OPTIMUM TRACKING
- 16" (406 MM) DIAMETER ALUMINUM HANDWHEEL
- $\phi 1 \frac{1}{8}$ ($\phi 29$ MM) S.STL. TRIPLE LEAD ACME ROD
- BRASS LIFTING NUT
- POLYMER BEARING PADS
- STAINLESS STEEL HARDWARE THROUGHOUT
- NON-OZONE DEPLETING BITUMINOUS COATING ON FRAME
- OPTIONAL CLEAR STEM COVER
- 3 YEAR GUARANTEE

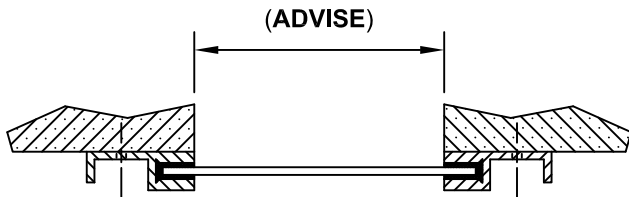
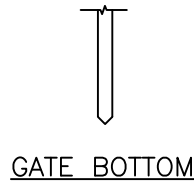
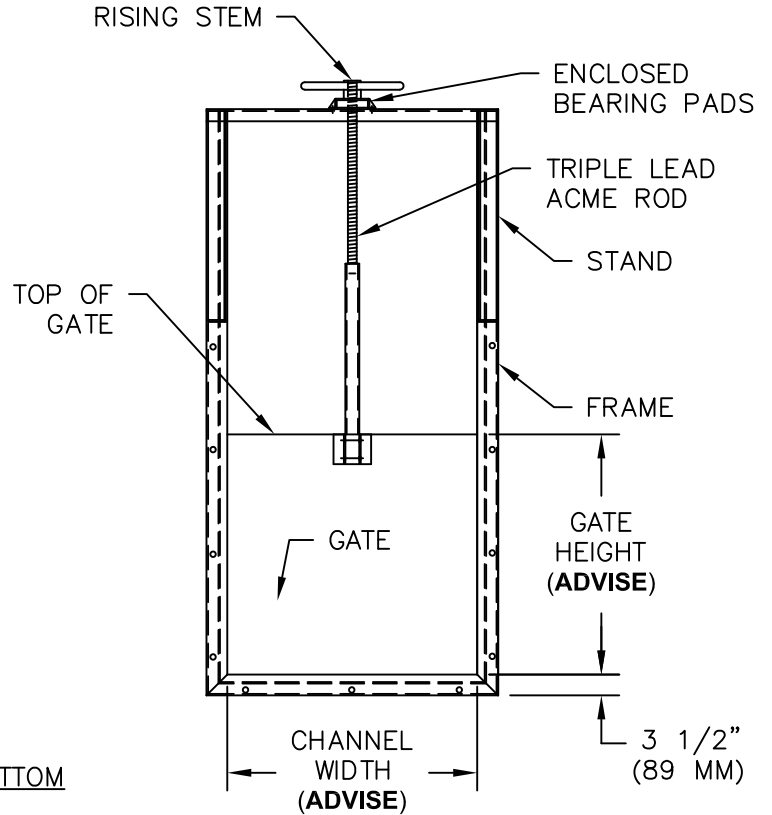
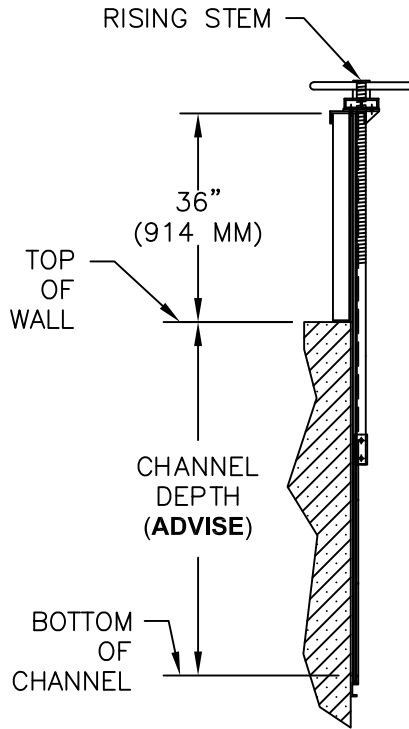
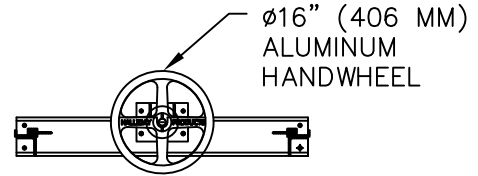

SERIES G1A
(WALL MOUNTED)

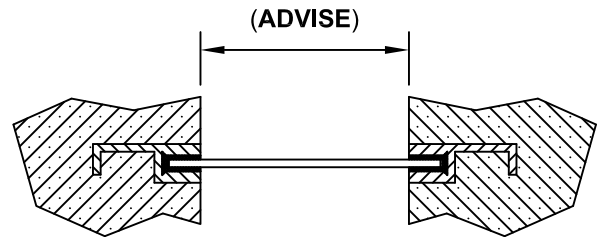

SERIES G1B
(EMBEDDED)