

# SERIES G1A AND G1B SLIDE GATES



www.HallidayProducts.com  
 Phone 800-298-1027  
 Fax 407-298-4534  
 Sales@HallidayProducts.com

## STANDARD FEATURES:

- ONE-PIECE 6061-T6 EXTRUDED ALUMINUM FRAME
- ONE-PIECE POLYMER GUIDE
- 1/4" (7 MM) THICK 6061-T6 ALUMINUM GATE REINFORCED AS REQUIRED TO DEFLECT NO MORE THAN 1/360th OF SPAN
- LOW COEFFICIENT OF FRICTION
- DEEP SEATING FOR OPTIMUM TRACKING
- STANDARD 16" (406 MM) ALUMINUM HANDWHEEL
- POLYMER BEARING PADS
- $\phi 1 \frac{1}{8}$ " ( $\phi 29$  MM) S.STL. TRIPLE LEAD ACME ROD
- BRASS LIFTING NUT
- STAINLESS STEEL HARDWARE THROUGHOUT
- NON-OZONE DEPLETING BITUMINOUS COATING
- OPTIONAL CLEAR STEM COVER
- 3 YEAR GUARANTEE



GATE BOTTOM

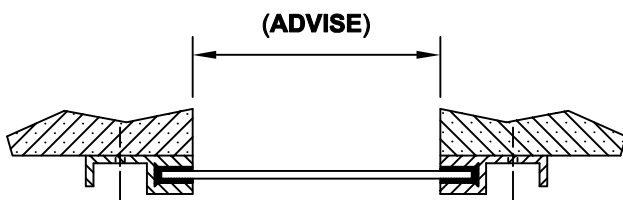
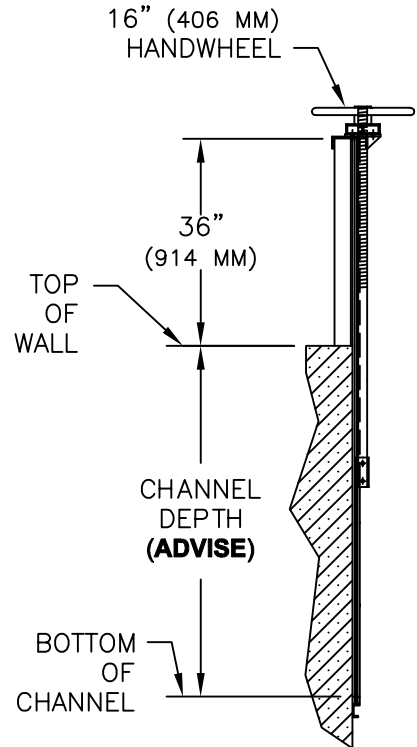
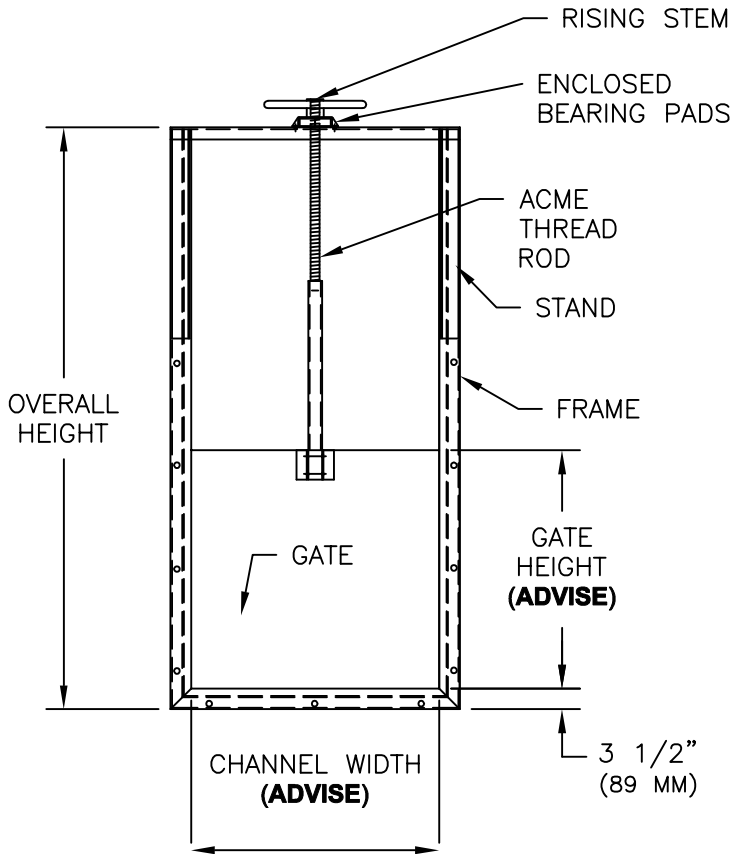

**SERIES G1A**  
(WALL MOUNTED)

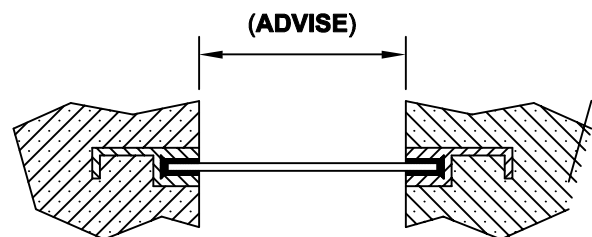

**SERIES G1B**  
(EMBEDDED)