

SERIES W1C & W2C ACCESS COVERS

TABLE OF CONTENTS

Vendor Data

Material Data Sheet

Specification

Component Parts List

Storage, Handling, Installation & Maintenance Instructions

Limited Warranty

VENDOR DATA

**HALLIDAY PRODUCTS, INC.
6401 Edgewater Drive
Orlando, FL 32810**

Phone: 407-298-4470 - Fax: 407-298-4534

Toll Free: 800-298-1027

Email: marketing@HallidayProducts.com

Web Site at www.HallidayProducts.com

Armond Bordeau, Contact

MATERIAL DATA SHEET

Access Frames and Covers

1. Door leaf shall be ¼-in. thick 5086-H34* mill finish aluminum diamond pattern plate, reinforced with a ¼-in. aluminum flat bar to attain 300 lb/ft² (1462 kg/m²) live load.
2. Frame members shall be ¼-in. thick 6005-T5 mill finish aluminum extrusion with built-in EPDM cushion/gasket and bituminous coating.
3. The following items shall be Type 316 stainless steel: hinges, hold-open arm, slamlock and all attaching hardware. The compression spring shall be Type 17-7 stainless steel.
4. Units shall carry a Lifetime Guarantee against defects in material and/or workmanship.

*5086-H34 has excellent resistance to corrosion--especially in a marine environment, good workability, weld ability, good finishing characteristics, and higher strength than 3003 or 5052.

Series W1C and W2C Access Covers

STANDARD FEATURES:

Stainless steel compression spring assist
Auto-lock, T316 stainless steel hold-open arm with release handles
T-316 stainless steel hinges and attaching hardware
T-316 stainless steel slam lock w/ removable key
Channel frame
Built-in EPDM cushion/gasket Non-ozone
depleting bituminous coating Single or
double leaf construction
300 lb/ft² (1462 kg/m²) live load
Lifetime guarantee

SPECIFICATION:

The W1C (single leaf) and W2C (double leaf) access frames and covers as manufactured by Halliday Products, Inc. of Orlando, Florida shall have a ¼-in. thick one-piece, mill finish, extruded aluminum channel frame, incorporating a continuous concrete anchor. A 1-½ in. drainage coupling shall be located in the front left corner of the channel frame. A bituminous coating shall be applied to the frame exterior where it will come in contact with concrete. Door panel(s) shall be ¼-in. aluminum diamond plate reinforced to withstand a 300 lb/ft² (1462 kg/m²) live load and shall not protrude into the channel frame when in the open position. Door(s) shall open to 90 degrees and automatically lock with T-316 stainless steel hold-open arm(s) with aluminum release handle(s). For ease of operation the hold-open arm shall incorporate enclosed stainless steel compression spring assists. Door(s) shall close flush with the frame and rest on a built-in EPDM cushion/gasket. Hinges and all fastening hardware shall be T-316 stainless steel. Unit shall lock with T-316 stainless steel slam lock with removable key and have a non-corrosive handle. Unit shall carry a Lifetime guarantee against defects in material and/or workmanship.



SERIES WIC

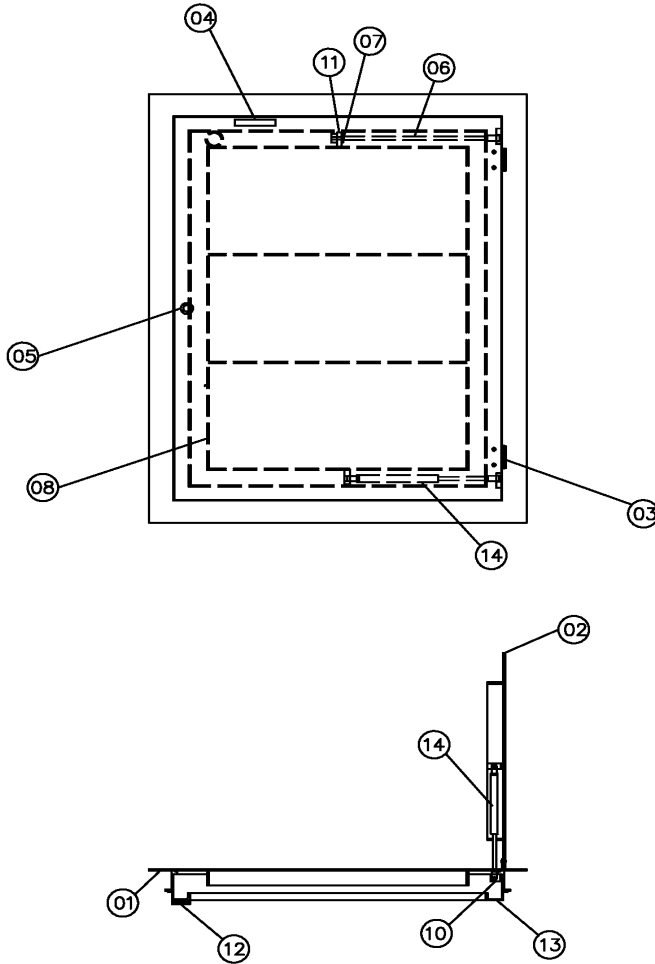

STANDARD COMPONENT PARTS

- ① FRAME EXTRUSION
- ② DIAMOND PLATE COVER
- ③ HINGES W/ HARDWARE
- ④ LIFTING HANDLE
- ⑤ LOCKING BAR
- ⑥ HOLD-OPEN ARM
- ⑦ POSITIVE LOCKING LATCH
- ⑧ COVER REINFORCEMENT
- ⑨ UPPER CLEVIS ASSEMBLY
- ⑩ LOWER CLEVIS ASSEMBLY
- ⑪ GUIDE PLATE
- ⑫ DRAIN COUPLING
- ⑬ ADD ON CHANNEL
- ⑭ SPRING

NOTE: Component Part Pricing:

Due to component part sizes and pricing change, Halliday Products Inc. does not list component part pricing. Halliday Products Inc. has a Limited Life Time Warranty on parts. See Warranty



SERIES WIC OPTIONS

- (A) SLAM LOCK
- (B) RECESSED LOCK BOX
- (C) SLAB SKIRTING
- (D) SAFETY POST & CHAIN
- (E) SAFETY POST & CABLE
- (F) NUT RAIL
- (G) INSULATION
- (H) SAFETY GRATING
- (I) GASKET
- (J) BOLT DOWN
- (K) SPRING ASSIST
- (L) KEYED CYLINDER LOCK

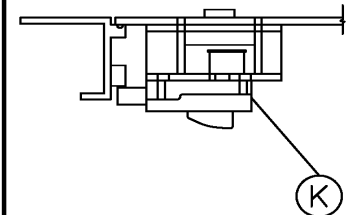
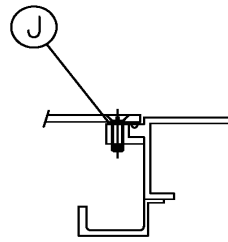
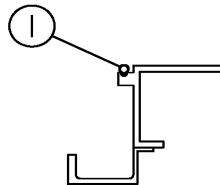
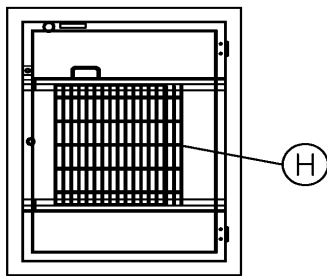
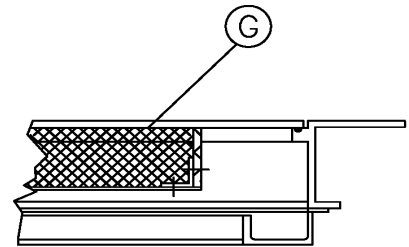
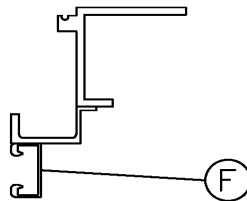
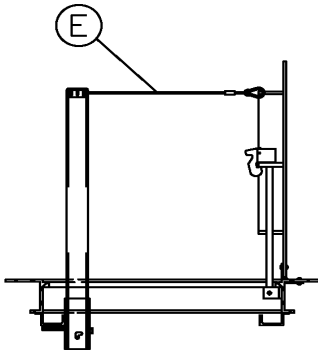
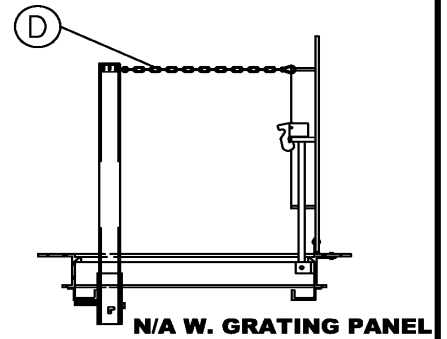
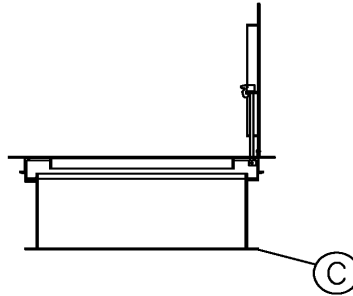
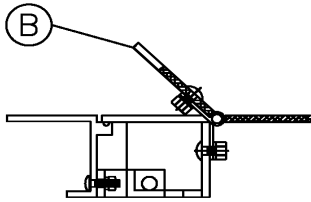
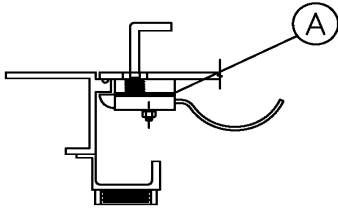



SERIES W2C

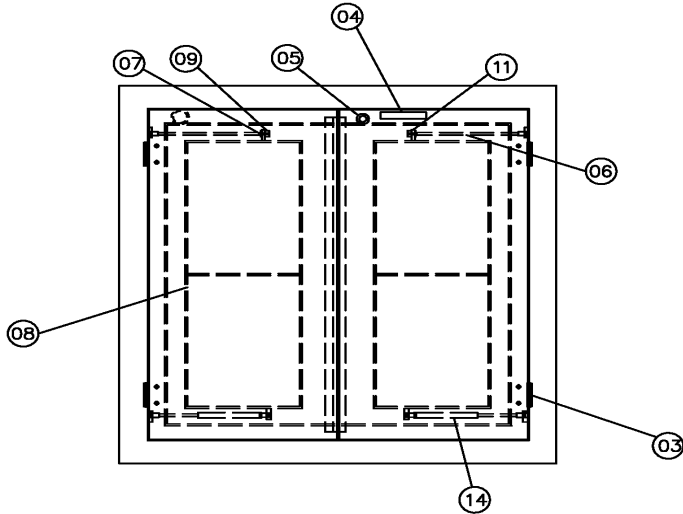

STANDARD COMPONENT PARTS

- ① FRAME EXTRUSION
- ② DIAMOND PLATE COVER
- ③ HINGES W/ HARDWARE
- ④ LIFTING HANDLE
- ⑤ LOCKING BAR
- ⑥ HOLD-OPEN ARM
- ⑦ POSITIVE LOCKING LATCH
- ⑧ COVER REINFORCEMENT
- ⑨ UPPER CLEVIS ASSEMBLY
- ⑩ LOWER CLEVIS ASSEMBLY
- ⑪ GUIDE PLATE
- ⑫ DRAIN COUPLING
- ⑬ ADD ON CHANNEL
- ⑭ SPRING

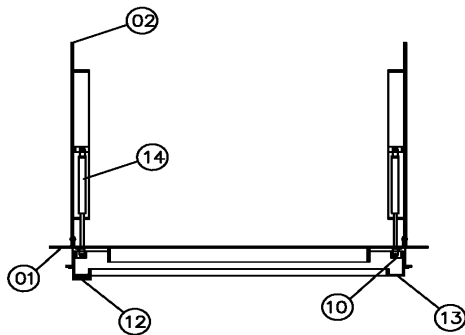

NOTE: Component Part Pricing:

Due to component part sizes and pricing change, Halliday Products Inc. does not list component part pricing. Halliday Products Inc. has a Limited Life Time Warranty on parts. See Warranty



SERIES W2C OPTIONS

- (A) LOCK BAR
- (B) KEYED CYLINDER LOCK
- (C) RECESSED LOCK BOX
- (D) SLAB SKIRTING
- (E) SAFETY CHAIN
- (F) SAFETY CABLE
- (G) NUT RAIL
- (H) INSULATION
- (I) SAFETY GRATING
- (J) BOLT DOWN

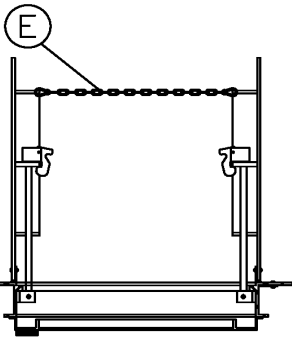
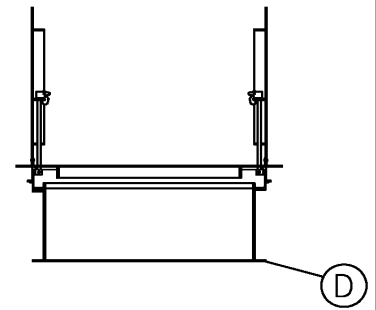
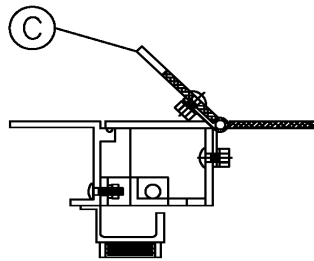
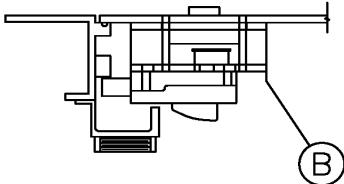
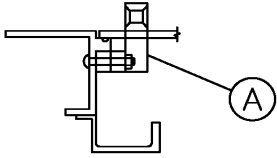

N/A W/ GRATING PANEL

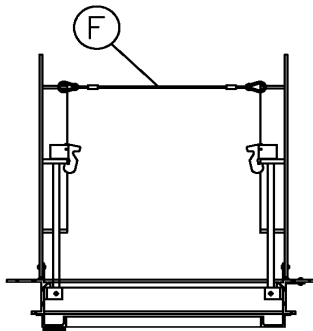

N/A W/ GRATING PANEL

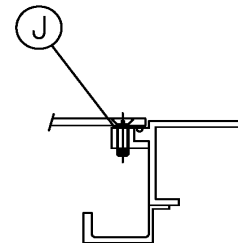
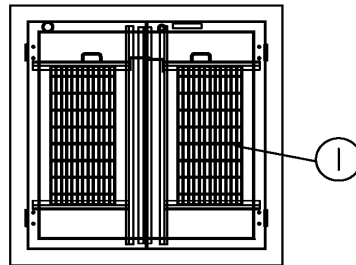
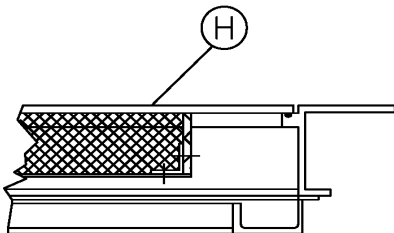
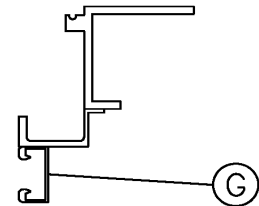

STORAGE, HANDLING, INSTALLATION and MAINTENANCE

STORAGE:

Prior to installation access covers should be stored in a dry area on the original shipping pallets.

HANDLING:

Standard practice precautions should be taken whenever handling or moving palletized access covers by forklift.

INSTALLATION:

For proper installation, Halliday Products, Inc. recommends the following:

1. Formwork must be flush to the inside of frame.
2. Secure unit to formwork using standard construction practices.
3. When pouring concrete, cover should be in the closed position.
4. Concrete to finish flush with top of unit framework.
5. Unit should be left in formwork for not less than 24 hours.
6. Clean all excess concrete from frame, over seat; and in the case of a channel frame model, the drainage coupling.

MAINTENANCE:

Because access covers manufactured by Halliday Products, Inc. are of all aluminum and stainless steel construction, they require minimal maintenance. For optimum product life the manufacturer recommends the following procedures be performed annually:

1. Apply graphite to the interior of all locking devices.
2. Apply a light coating of machine oil to all hinges and hardware.
3. Remove all debris from the cover seat and around hinges.
4. Check and tighten any loose hardware.
5. In the case of a channel frame model, remove loose debris from channel.



LIMITED WARRANTY

Halliday Products, Inc., a Florida Corporation (“Company”) warrants to the original customer the aluminum access frame and cover will be free from defective material or faulty workmanship for the life of the unit. In the event of malfunction or other indication of failure attributable directly to defective material or faulty workmanship, Company will, upon receipt of a written notification from customer of such defective material or faulty workmanship, at its option and expense, repair or replace the defective frame and cover, or a component thereof, to whatever extent Company shall deem necessary to restore the frame and cover, or a component thereof, to proper operating condition. Company may replace the defective frame and cover, or a component thereof, with either a new or remanufactured, functionally equivalent frame and cover or component thereof at the Company’s option. **THIS WARRANTY IS EXCLUSIVE AND IN LIEU OF ALL OTHER WARRANTIES, WHETHER OR NOT STATUTORY, OR EXPRESSED OR IMPLIED, INCLUDING WITHOUT LIMITATION, THE IMPLIED WARRANTIES OF MERCHANTABILITY AND FITNESS FOR A PARTICULAR PURPOSE. THE EXCLUSIVE REMEDY FOR DEFECTIVE FRAME AND COVER SHALL BE ONLY IN CONTRACT, WHETHER OR NOT CAUSED BY A DEFECTIVE FRAME AND COVER, OR NEGLIGENCE. COMPANY’S LIABILITY FOR LOSS OR DAMAGES SHALL NOT EXCEED THE PRICE PAID BY CUSTOMER FOR THE FRAME AND COVER, REGARDLESS OF THE FORM OF ANY CLAIM. IN NO EVENT SHALL COMPANY BE LIABLE FOR ANY SPECIAL, INCIDENTAL, INDIRECT, CONSEQUENTIAL, OR PUNITIVE DAMAGES WHATSOEVER RESULTING FROM ANY DEFECTIVE FRAME AND COVER OR COMPONENT THEREOF. IF MODIFICATION OR ALTERATION IS MADE TO THE FRAME AND COVER OR COMPONENT THEREOF BY OTHER THAN COMPANY AUTHORIZED PERSONS, OR IF IT IS INSTALLED IMPROPERLY, OR MISUSED, ABUSED AND/OR NEGLECTED, THIS LIMITED WARRANTY IS NULL AND VOID AND OF NO EFFECT. THIS LIMITED WARRANTY DOES NOT APPLY AND THE COMPANY WILL HAVE NO RESPONSIBILITY HEREUNDER FOR NORMAL WEAR AND TEAR.**

Halliday Products, Inc.
6401 Edgewater Dr
Orlando, FL 32810
Toll Free: 800-298-1027
Fax: 407-298-4534
Email: Marketing@HallidayProducts.com