

SERIES V4A TELESCOPING VALVE

Type 304 Stainless Steel

TABLE OF CONTENTS

V e n d o r D a t a

A p p l i c a t i o n a n d S p e c i f i c a t i o n

I n s t a l l a t i o n a n d M a i n t e n a n c e I n s t r u c t i o n s

L i m i t e d W a r r a n t y

VENDOR DATA

**HALLIDAY PRODUCTS, INC.
6401 Edgewater Drive
Orlando, FL 32810**

Phone: 407-298-4470 - Fax: 407-298-4534

Toll Free: 800-298-1027

Email: marketing@HallidayProducts.com

Web Site at www.HallidayProducts.com

Armond Bordeau, Contact

Series V4A Telescoping Valve

STANDARD FEATURES:

T304 Stainless steel construction (Consult factory for T316 stainless steel availability)

Polymer bearing pads

Round 1-1/8-in. stainless steel triple lead acme rod

Stainless steel companion flange

1/4-in. thick neoprene wipe gasket

Non-Rising stem

Level indicator

3-year limited warranty

SPECIFICATION:

The telescoping valve assembly shall be manufactured by Halliday Products, Inc. of Orlando, Florida. The telescoping valve shall be sized to fit riser pipe and penetrate the riser pipe a minimum of 9-in. in the up position. The unit shall have a floor stand of 4-in. square stainless steel tube with 1/8-in. wall and mounted to a 1/2-in. thick stainless steel base plate. The handwheel shall be 16-in. diameter cast aluminum and work in conjunction with a brass lifting nut and 1-1/8-in. diameter stainless steel triple lead acme rod, requiring a maximum of 16 turns for one foot of travel. Polymer bearing pads shall be incorporated above and below the brass nut. The slip tube shall be a minimum of 16-ga. stainless steel and incorporate a 150 lbs. stainless steel companion flange and two (2) 1/4-in. thick neoprene wipe gaskets. Unit shall be guaranteed against defects in material and/or workmanship for a period of 3 years.

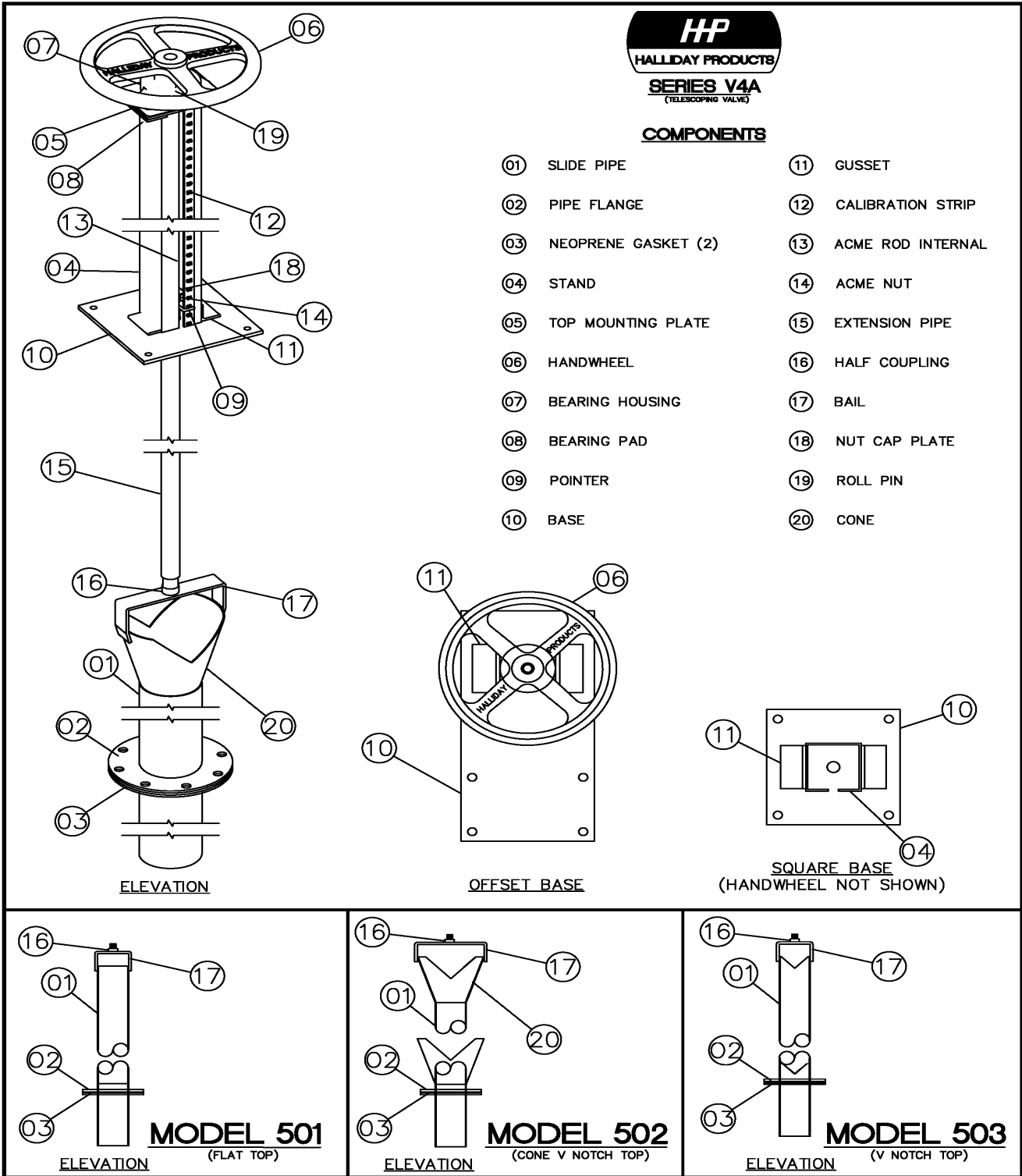

NOTE: Component Part Pricing:

Due to component part sizes and pricing change, Halliday Products Inc. does not list component part pricing. Halliday Products Inc. has a Limited Life Time Warranty on parts. See Warranty

Installation, Operation and Maintenance **INSTALLATION:**

The Halliday Products Series V4A acme rod-style telescoping valve relies upon proper installation to insure a long life of reliable operation. Although installation is uncomplicated, proper alignment is critical:

1. Verify that riser pipe is unobstructed.
2. Line up the valve flange and two (2) neoprene wipe gaskets with the flange on the riser pipe until the base plate contacts the mounting surface. To insure proper alignment the slip tube must be plumb in all directions.
3. Secure base plate to the concrete with (4) anchoring devices per contract specifications.
4. Operate valve through a complete travel to insure it is in good working condition.

OPERATION:

The Halliday Products telescoping valve has been engineered to afford ease of operation so excessive handwheel torque is neither required nor advised. Do not use cheater bars or extensions to turn the handwheel. The handwheel assembly and/or the stem may be damaged thereby. If the valve does not operate smoothly:

1. Check alignment of valve, which must be plumb in all directions.
2. Check for obstructions in the existing riser pipe.
3. Remove dried, hardened lubricant from operating stem, and apply new coating of lubricant.
4. Disengage locking mechanism.
5. Turn the handwheel clockwise to travel up and counter-clockwise to travel down.

MAINTENANCE:

The Halliday Products telescoping valve is manufactured of only nonferrous metals that require little or no maintenance. For ease of operation and long product life, Halliday Products recommends the following:

1. Once yearly clean and remove any debris.



LIMITED WARRANTY

Halliday Products, Inc., a Florida Corporation (“Company”) warrants to the original customer the stainless steel telescoping valve will be free from defective material or faulty workmanship for a period of three (3) years from date of purchase by Customer. In the event of malfunction or other indication of failure attributable directly to defective material or faulty workmanship, Company will, upon receipt of a written notification from customer of such defective material or faulty workmanship, at its option and expense, repair or replace the defective telescoping valve, or a component thereof, to whatever extent Company shall deem necessary to restore the telescoping valve, or a component thereof, to proper operating condition. Company may replace the defective telescoping valve, or a component thereof, with either a new or remanufactured, functionally equivalent telescoping valve or component thereof at the Company’s option. **THIS WARRANTY IS EXCLUSIVE AND IN LIEU OF ALL OTHER WARRANTIES, WHETHER OR NOT STATUTORY, OR EXPRESSED OR IMPLIED, INCLUDING WITHOUT LIMITATION, THE IMPLIED WARRANTIES OF MERCHANTABILITY AND FITNESS FOR A PARTICULAR PURPOSE. THE EXCLUSIVE REMEDY FOR DEFECTIVE TELESCOPING VALVE SHALL BE ONLY IN CONTRACT, WHETHER OR NOT CAUSED BY A DEFECTIVE TELESCOPING VALVE, OR NEGLIGENCE. COMPANY’S LIABILITY FOR LOSS OR DAMAGES SHALL NOT EXCEED THE PRICE PAID BY CUSTOMER FOR THE TELESCOPING VALVE, REGARDLESS OF THE FORM OF ANY CLAIM. IN NO EVENT SHALL COMPANY BE LIABLE FOR ANY SPECIAL, INCIDENTAL, INDIRECT, CONSEQUENTIAL, OR PUNITIVE DAMAGES WHATSOEVER RESULTING FROM ANY DEFECTIVE TELESCOPING VALVE OR COMPONENT THEREOF. IF MODIFICATION OR ALTERATION IS MADE TO THE TELESCOPING VALVE OR COMPONENT THEREOF BY OTHER THAN COMPANY AUTHORIZED PERSONS, OR IF IT IS INSTALLED IMPROPERLY, OR MISUSED, ABUSED AND/OR NEGLECTED, THIS LIMITED WARRANTY IS NULL AND VOID AND OF NO EFFECT. THIS LIMITED WARRANTY DOES NOT APPLY AND THE COMPANY WILL HAVE NO RESPONSIBILITY HEREUNDER FOR NORMAL WEAR AND TEAR.**

Halliday Products, Inc.
6401 Edgewater Dr
Orlando, FL 32810
Toll Free: 800-298-1027
Fax: 407-298-4534
Email: Marketing@HallidayProducts.com