

# **SERIES DB PORTABLE HOIST**

## **TABLE OF CONTENTS**

**V e n d o r   D a t a**

**A p p l i c a t i o n   a n d   S p e c i f i c a t i o n**

**O p e r a t i o n   a n d   M a i n t e n a n c e   I n s t r u c t i o n s**

**L i m i t e d   W a r r a n t y**

**VENDOR DATA**

**HALLIDAY PRODUCTS, INC.  
6401 Edgewater Drive  
Orlando, FL 32810**

**Phone: 407-298-4470 - Fax: 407-298-4534**

**Toll Free: 800-298-1027**

**Email: [marketing@HallidayProducts.com](mailto:marketing@HallidayProducts.com)**

**Web Site at [www.HallidayProducts.com](http://www.HallidayProducts.com)**

**Armond Bordeau, Contact**

## **Series DB Adjustable-Reach Portable Hoist**

### **APPLICATION:**

The adjustable-reach series DB stainless steel portable hoist is commonly used to raise and lower pumps and other equipment at wet well locations. Unit is supplied with a marine grade manually operated brake winch with 30 feet of 1/4" stainless steel cable and galvanized safety hook. The adjustable reach is from 24 to 36 inches in 1" increments. The overall height of the unit is 60", with a net lift of 49 inches for a 24" reach to 34 inches for a 36" reach. Units with maximum load ratings of 300, 1000 and 1330 lbs. are available. Socket choices are embedded, wall mounted and floor mounted. Unit is not suitable for confined space applications or where raising or lowering of a human is required.

### **SPECIFICATION:**

The portable hoist shall be series DB as manufactured by Halliday Products, Inc. of Orlando, Florida. The unit shall be sized to facilitate equipment placement and removal. The portable hoist shall be all Type 304 stainless steel construction with marine grade brake winch and 30 feet of 1/4" Type 304 stainless steel cable with galvanized safety hook. The davit arm shall adjust in 1" increments from 24" to 36" and the overall unit height shall be 60". The portable hoist shall be guaranteed against defects and material and/or workmanship for a period of 3 years.



**SERIES D1B, D2B, D3B**  
(HOIST)

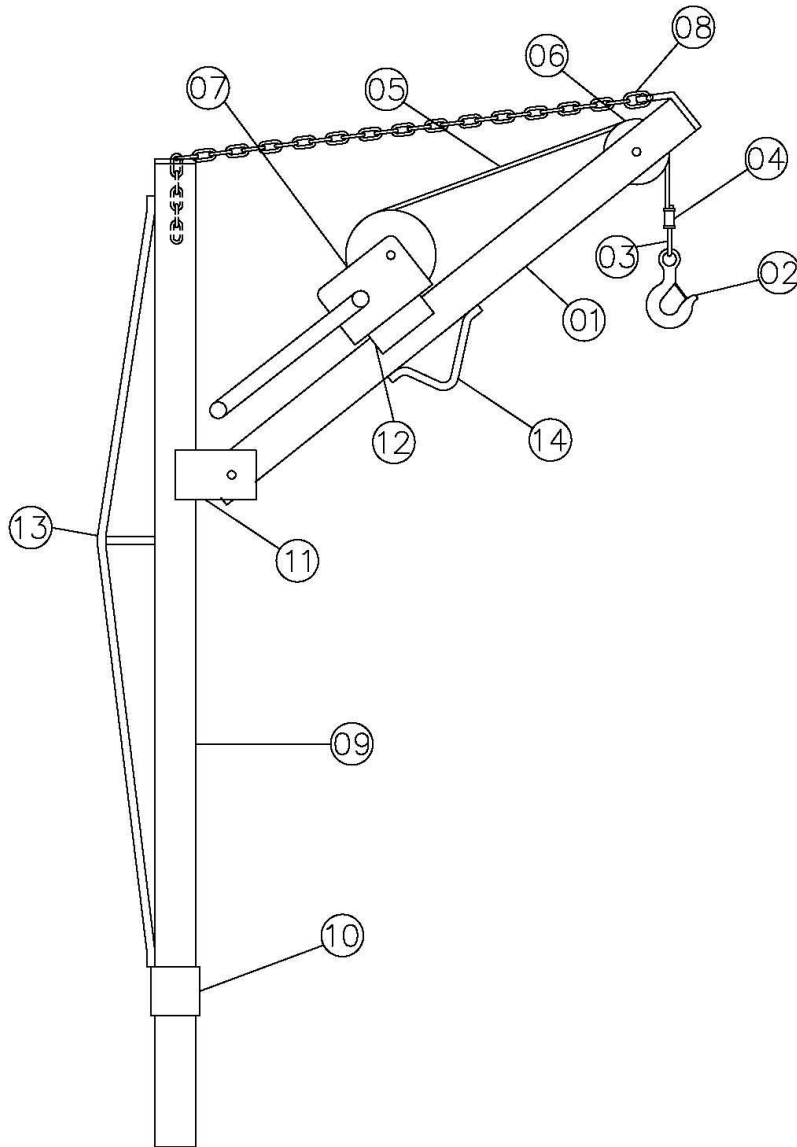

**STANDARD COMPONENT PARTS**

- ① BOOM
- ② STD. HOOK
- ③ THIMBLE
- ④ COMPRESSION SLEEVE
- ⑤ CABLE
- ⑥ PULLEY
- ⑦ WINCH
- ⑧ CHAIN
- ⑨ MAST
- ⑩ MAST COLLAR
- ⑪ BOOM PIVOT PLATE
- ⑫ WINCH MOUNTING PLATE
- ⑬ MAST BACK BRACE
- ⑭ STATIC HOOK



**SERIES D-E, D-W, AND D-S**

STANDARD FEATURES:

- STAINLESS STEEL TYPE-304 (STANDARD) OR TYPE-316 (OPTIONAL) CONSTRUCTION
- AVAILABLE IN 3 STYLES
- AVAILABLE WITH POLYMER LINING FOR SMOOTHER ROTATION

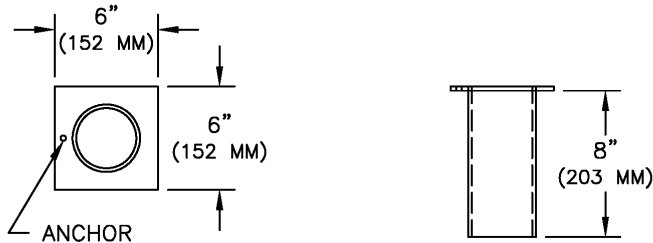

PLAN

ELEVATION

EMBED STYLE HOIST SOCKETS	
SOCKET MODEL #	FOR HOIST MODELS
D1E UNLINED	D1A AND D1B
D2E UNLINED	D2A AND D2B
D3E UNLINED	D3A AND D3B
D1R LINED	D1A AND D1B
D2R LINED	D2A AND D2B
NOT AVAILABLE	D3A AND D3B

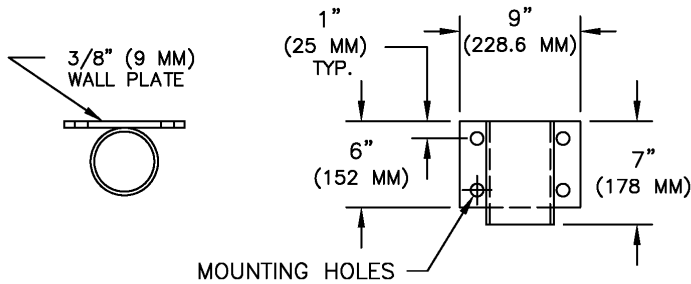

PLAN

ELEVATION

WALL STYLE HOIST SOCKETS	
SOCKET MODEL #	FOR HOIST MODELS
D1W UNLINED	D1A AND D1B
D2W UNLINED	D2A AND D2B
NOT AVAILABLE	D3A AND D3B
D1V LINED	D1A AND D1B
D2V LINED	D2A AND D2B
NOT AVAILABLE	D3A AND D3B

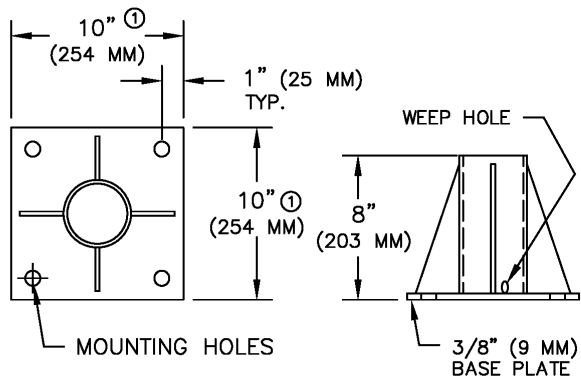

PLAN

ELEVATION

FLOOR STYLE HOIST SOCKETS	
SOCKET MODEL #	FOR HOIST MODELS
D1F UNLINED	D1A AND D1B
D2F UNLINED	D2A AND D2B
D3F UNLINED	D3A AND D3B
D1S LINED	D1A AND D1B
D2S LINED	D2A AND D2B
NOT AVAILABLE	D3A AND D3B

NOTES:  
 D1 AND D2 MOUNTING HOLES ARE  $\phi 3/4$ " ( $\phi 19$  MM)  
 D3 MOUNTING HOLES ARE  $\phi 7/8$ " ( $\phi 305$  MM)

① D3 BASE PLATE 12" X 12" (305 MM X 305 MM)

## Installation and Operation

### **OPERATION:**

The Halliday Products portable hoist assembly has been engineered for basic hoisting requirements of relatively light equipment. This unit should never be used to move people, nor should the equipment weight be greater than the load capacity. To properly operate this unit, Halliday Products recommends the following:

1. Ready equipment for hoisting by including the following:
  - A) Proper and positive cable attachment.
  - B) Equipment freed to ascend, with all obstacles having been removed from path.
  - C) Equipment guide rails, if required, free of all debris.
2. When lowering cable, a minimum load is required.
3. Never stand beneath equipment being raised or lowered.
4. Store unit with safety hook attached at static loop.
5. Cable and all connections should be inspected biannually for evidence of wear.

### **MAINTENANCE:**

The Halliday Products adjustable reach portable hoist requires little or no maintenance. For ease of operation and long product life, Halliday Products recommends the following:

1. Once yearly new lubricant should be applied to the sheave axle and socket.
2. Accompanying sockets should be kept clear of all debris.
3. Winch and sheave should be kept clear of all cable-carried debris.



## LIMITED WARRANTY

Halliday Products, Inc., a Florida Corporation (“Company”) warrants to the original customer the stainless steel portable hoist will be free from defective material or faulty workmanship for a period of three (3) years from date of purchase by Customer. In the event of malfunction or other indication of failure attributable directly to defective material or faulty workmanship, Company will, upon receipt of a written notification from customer of such defective material or faulty workmanship, at its option and expense, repair or replace the defective portable hoist, or a component thereof, to whatever extent Company shall deem necessary to restore the portable hoist, or a component thereof, to proper operating condition. Company may replace the defective portable hoist, or a component thereof, with either a new or remanufactured, functionally equivalent portable hoist or component thereof at the Company’s option. **THIS WARRANTY IS EXCLUSIVE AND IN LIEU OF ALL OTHER WARRANTIES, WHETHER OR NOT STATUTORY, OR EXPRESSED OR IMPLIED, INCLUDING WITHOUT LIMITATION, THE IMPLIED WARRANTIES OF MERCHANTABILITY AND FITNESS FOR A PARTICULAR PURPOSE. THE EXCLUSIVE REMEDY FOR DEFECTIVE PORTABLE HOIST SHALL BE ONLY IN CONTRACT, WHETHER OR NOT CAUSED BY A DEFECTIVE PORTABLE HOIST, OR NEGLIGENCE. COMPANY’S LIABILITY FOR LOSS OR DAMAGES SHALL NOT EXCEED THE PRICE PAID BY CUSTOMER FOR THE PORTABLE HOIST, REGARDLESS OF THE FORM OF ANY CLAIM. IN NO EVENT SHALL COMPANY BE LIABLE FOR ANY SPECIAL, INCIDENTAL, INDIRECT, CONSEQUENTIAL, OR PUNITIVE DAMAGES WHATSOEVER RESULTING FROM ANY DEFECTIVE PORTABLE HOIST OR COMPONENT THEREOF. IF MODIFICATION OR ALTERATION IS MADE TO THE PORTABLE HOIST OR COMPONENT THEREOF BY OTHER THAN COMPANY AUTHORIZED PERSONS, OR IF IT IS INSTALLED IMPROPERLY, OR MISUSED, ABUSED AND/OR NEGLECTED, THIS LIMITED WARRANTY IS NULL AND VOID AND OF NO EFFECT. THIS LIMITED WARRANTY DOES NOT APPLY AND THE COMPANY WILL HAVE NO RESPONSIBILITY HEREUNDER FOR NORMAL WEAR AND TEAR.**

Halliday Products, Inc.  
6401 Edgewater Dr  
Orlando, FL 32810  
Toll Free: 800-298-1027  
Fax: 407-298-4534  
Email: [Info@HallidayProducts.com](mailto:Info@HallidayProducts.com)